

1" COMMERCIAL DROP ROD

www.nationwideindustries.com

INSTALLATION, ADJUSTMENT AND MAINTENANCE INSTRUCTIONS

INSTALLATION

1. Insert the DROP ROD into the GUIDE, and orient the DROP ROD in the "locked" position as shown (Figure 1). The middle RETENTION EAR should be resting on the top face of the GUIDE.
2. Hold the GUIDE and DROP ROD against the GATE, and position it so that the DROP ROD does not drag when the GATE is being moved. Align the DROP ROD with the hole in the ground and make sure that the DROP ROD will be able to lower enough to lock the GATE (see OPERATION section below for instructions on lowering the rod). Mark the locations of the two MOUNTING HOLES on the GATE, and then remove the GUIDE and DROP ROD from the gate (Figure 2). Drill clearance holes through the GATE at each of the marked locations using a 25/64" drill bit.
3. Remove the DROP ROD from the GUIDE. Insert the two 3/8" BOLTS through the MOUNTING HOLES as shown, and then reinsert the DROP ROD into the GUIDE (Figure 3).
4. Mount the DROP ROD to the GATE using the two BOLTS through the drilled MOUNTING HOLES, with a NUT for each BOLT on the other side of the GATE (Figure 4).

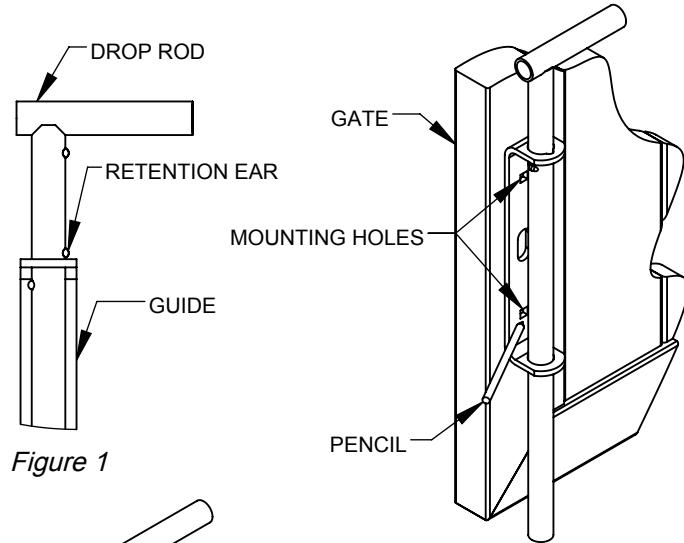

Figure 1

Figure 2

OPERATION

1. To set the GATE in place, rotate the DROP ROD 90° clockwise to allow the middle RETENTION EAR to pass through the opening, and lower the DROP ROD into the aligned hole in the ground. Then rotate the DROP ROD back 90° counterclockwise to lock in place (Figure 5).
2. To disengage the GATE, rotate the DROP ROD 90° clockwise, and lift the DROP ROD until the middle RETENTION EAR passes through the top of the GUIDE. Rotate the DROP ROD back 90° counterclockwise to lock in place.

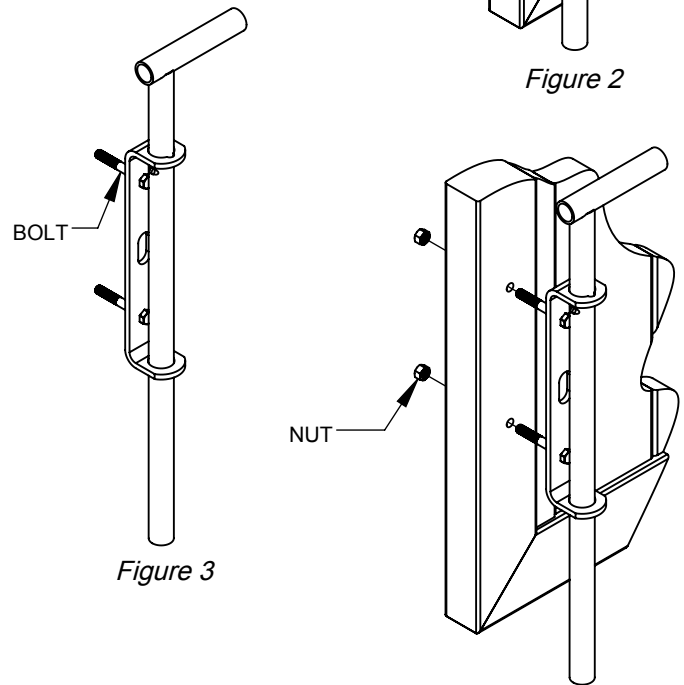

Figure 3

Figure 4

LOCKING (NW6270L)

1. With the DROP ROD in position as indicated under OPERATION step 1, insert the LOCKING TAB into the SLOT in the DROP ROD (Figure 6). Place a PADLOCK through the hole in the LOCKING TAB to prevent tab removal (Figure 7). The DROP ROD is now locked into place.
2. To unlock the DROP ROD, remove the PADLOCK from the LOCKING TAB, then pull the LOCKING TAB out of the DROP ROD.

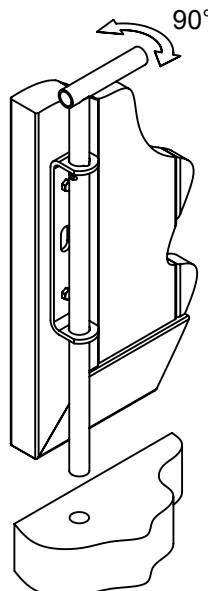

Figure 5

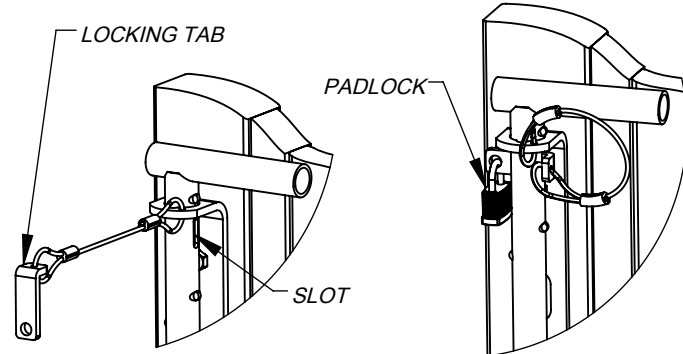

Figure 6

Figure 7